



GOVERNMENT OF TAMILNADU

DIRECTORATE OF TECHNICAL EDUCATION

**DIPLOMA IN ENGINEERING
I YEAR**

SEMESTER SYSTEM

L - SCHEME

2011 - 2012

I SEMESTER

ENGINEERING GRAPHICS - I

CURRICULUM DEVELOPMENT CENTER

STATE BOARD OF TECHNICAL EDUCATION & TRAINING, TAMILNADU
DIPLOMA IN ENGINEERING - SYLLABUS
L-SCHEME

(Implements from the Academic Year 2011-2012 on wards)

Course Name : All Branches of Diploma in Engineering and Technology and Special Programmes except DMOP, HMCT and Film & TV

Subject Code : **21006**

Semester : I Semester

Subject Title : **ENGINEERING GRAPHICS – I**

Objectives

At the end of the practice, the students will be able,

To state the importance of drawing.

To identify the drawing instruments.

To practice the methods of dimensioning.

To construct conics and special curves.

To trace the projection of points and straight lines.

To draw orthographic views from isometric drawings.

SCHEME OF INSTRUCTION AND EXAMINATION

No. of Weeks per Semester: 16 Weeks

Subject	Instruction		Examination			Duration
	Hours / Week	Hours / Semester	Marks			
			Internal	Examination	Total	
ENGINEERING GRAPHICS - I	6	96	25	75	100	3 Hrs.

TOPICS AND ALLOCATION

Sl.No.	Topics	Hours.
1	Drawing office practice	12 Hrs.
2	Constructions of conics and special curves	24 Hrs.
3	Projection of points and straight lines	12 Hrs
4	Orthographic projections	39 Hrs.
	Test	9 Hrs.

DETAILED SYLLABUS

Unit-1

12 Hrs.

1. 1. Drawing office practice

- 1.1.1 Importance of engineering drawing - drawing instruments: drawing board, mini drafter, compass, divider, protractor, drawing sheets etc., - layout of drawing sheets.
- 1.1.2 Importance of legible lettering and numbering - single stroke letters - upper case and lower case letters- general procedures for lettering and numbering - height of letters - guidelines.
- 1.1.3 Dimensioning - Need for dimensioning - terms and notations as per BIS - Dimension line, Extension line and Leader line - Methods of dimensioning – Importance of dimensioning rules - Exercises.
- 1.1.4 Scales - Study of scales - full size scale, reduced scale and enlarged scale.

Unit-2

24 Hrs.

2.1 Constructions of conics .

- 2.1.1 Conics: Different types – Definition of locus, focus and directrix - Applications of ellipse, parabola and hyperbola.
- 2.1.2 Ellipse: Construction of ellipse by concentric circle method, rectangular method and Eccentricity method when focus and directrix are given – Practical applications.
- 2.1.3 Parabola: Construction of parabola by rectangular method, parallelogram method and eccentricity method when focus and directrix are given– Practical applications.
- 2.1.4 Hyperbola: Construction of hyperbola by rectangular method and eccentricity method when focus and directrix are given– Practical applications.

2.2 Constructions of special curves.

- 2.2.1 Geometric curves: Definition, application and construction of cycloid - epicycloid – hypocycloid – exercises.
- 2.2.2 Involute of a circle - Archimedean spiral – helix – exercises.

Unit-3

12 Hrs.

3.1 Projection of points.

- 3.1.1 Projection of points – points in different quadrants.

3.2 Projection of straight lines.

- 3.2.1 Projection of straight lines – parallel to one plane and perpendicular to other plane – inclined to one plane and parallel to the other plane – parallel to both the planes – inclined to both the planes (simple problems only).

Unit-4

4.1. Orthographic projection

39 Hrs.

- 4.1.1 Introduction – projection terms - Orthographic projection - Co-ordinate planes of projection - Systems of orthographic projection - First angle orthographic projection- Third angle orthographic projection - Comparison of first and third angle projections.
- 4.1.2 Projection of three views (Elevation, Plan, Side view) of simple objects using first angle projection only - exercises.

TEST

9 Hrs.

Text Books

1. Gill P.S., "Engineering drawing", S.K.Kataria & Sons.
2. Bhat N.D., "Engineering drawing", Charotar Publishing House.

Reference Books

1. Gopalakrishnan.K.R., "Engineering Drawing", (Vol.I and Vol.II), Dhanalakshmi publishers, Edition 2, 1970
2. Venugopal.K, Sreekanjana G, "Engineering Graphics" New Age International Publishers.
3. K V Nataraajan "A Text Book of Engineering Drawing"
4. Thomas E.French, Charles J.Vierck, Robert J.Foster, "Engineering drawing and graphic technology", McGraw Hill International Editions.
5. Barkinson & Sinha, "First Year Engineering Drawing", Pitman Publishers.
6. Shah/Rana, "Engineering Drawing", Pearson Longman.

ENGINEERING GRAPHICS – I
I Semester

Learning Structure:

Problem

To acquire the skill of visualizing, interpreting and drawing the curves, projection of points and straight lines and orthographic projections.



Procedure

Read, understand, visualize, interpret and draw engineering curves, projection of points and straight lines and orthographic projections

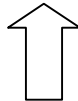

Principles

Diagonal scale, plain scale, dimensioning techniques and orthographic projections by 1st angle method

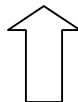

Concept

First angle and Third angle method - projections-dimensioning - engineering drawings as per IS Code.



Facts

Various objects, geometric entities, line, arc, circles, , drawing instruments

Board Examination – QUESTION PATTERN

Time: 3 Hrs.

Max.Marks: 75

[Note: Answer all the questions in the drawing sheet.]

Part A (Answer any four questions. Each question carries TEN marks.) 4X10 =**40 marks**

1. One question from dimensioning.
2. Three questions form construction of conics (Ellipse, Parabola and Hyperbola) and special curves. **At least one question from special curves should be asked.**
3. One question from projection of straight lines.

Part B (Draw three views in the first angle projection.)

35 marks

4. One question for orthographic projection.

Internal Marks

25 marks

Class work - submission of drawing sheets	-	10 marks
Test (including model examination)	-	10 marks
Attendance	-	5 marks
Total	-	25 marks

ENGINEERING GRAPHICS - I
MODEL QUESTION PAPER - 1

Time : 3Hours

Max. Marks : 75

[N.B. (1) First angle projection is to be followed. (2) All the questions are to be answered in drawing sheet supplied. (3) All dimensions are in mm. (4) Credit will be given for neatness.]

PART-A (Answer any four questions. Each question carries ten marks.)

4 X 10 = 40

1. Read the dimensioned drawing shown in fig.1. Redraw the figure to full size and dimension it as per Indian Standards.

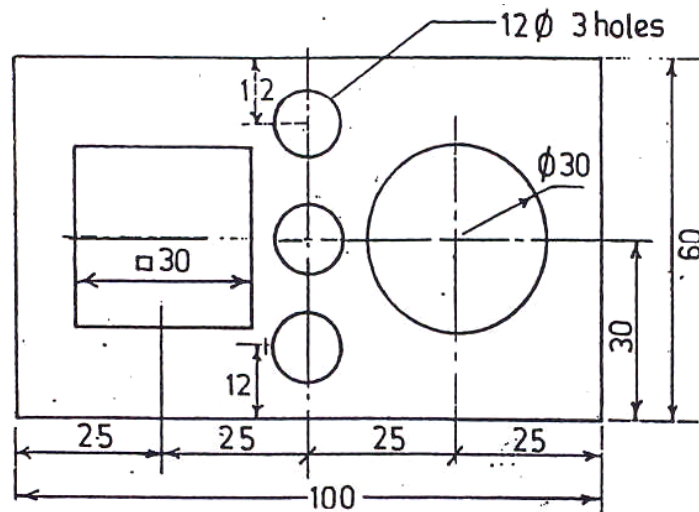

Fig. 1

2. A cricket ball thrown from the ground level reaches the wicket keeper's gloves. Maximum height reached by the ball is 5m. The ball travels a horizontal distance of 11m from the point of projection. Trace the path of the ball.
3. The head lamp reflector of a motor car has a maximum rim diameter of 130mm and maximum depth of 100 mm. Draw the profile of the reflector and name it.
4. Draw the cycloid formed by rolling circle of 50 mm in diameter.
5. A line AB 60 mm long has its end A in both the H.P. and V.P. it is inclined at 45° to H.P. and 30° to V.P. Draw the projections of the line AB.

Part B

35 marks

6. The Pictorial view of an object is shown in fig.3. Draw the following views to full size scale.

- a) Elevation in the direction of arrow - 15 Marks
- b) Left end elevation - 10 Marks
- c) Plan - 10 Marks

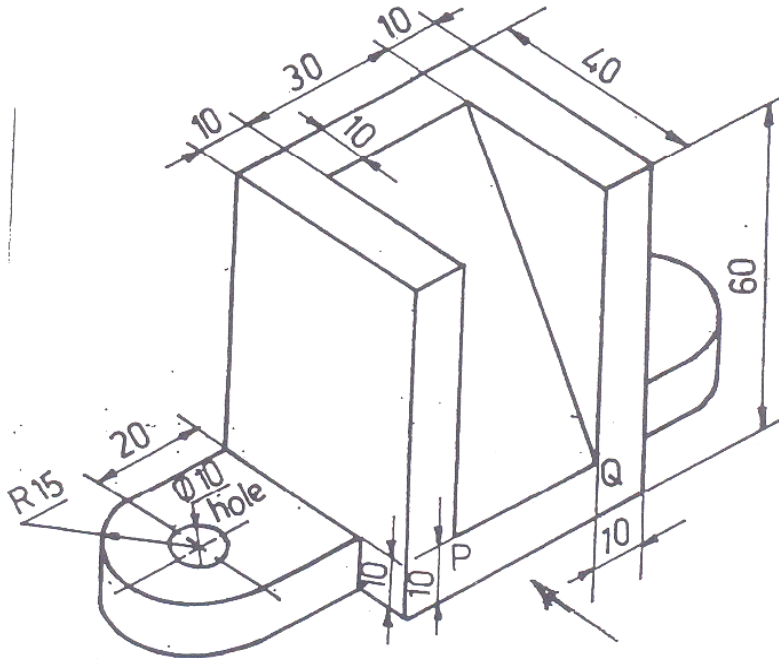

ENGINEERING GRAPHICS - I
MODEL QUESTION PAPER - 2

Time : 3Hours

Max. Marks : 75

[N.B. (1) First angle projection is to be followed. (2) All the questions are to be answered in drawing sheet supplied. (3) All dimensions are in mm. (4) Credit will be given for neatness.]

PART-A (Answer any four questions. Each question carries ten marks.)

4 X 10 = 40

1. Read the dimensioned drawing shown in fig.1. Redraw the figure to full size and dimension it as per Indian Standards.

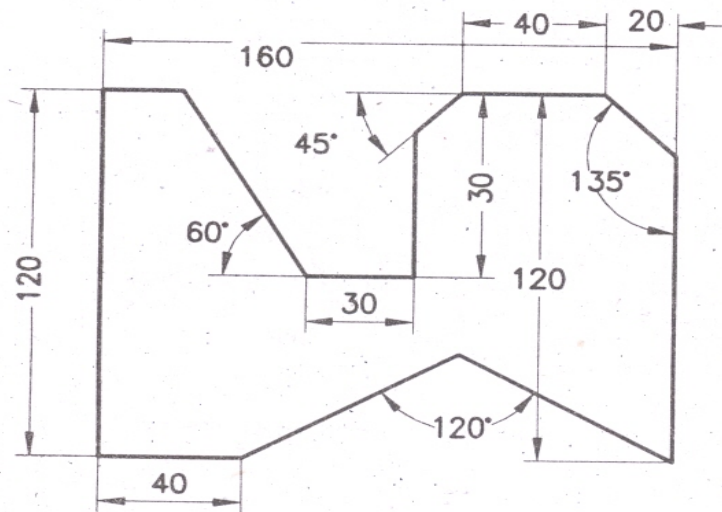

Fig. 1

2. A flowerbed in a botanical garden is in elliptical shape with major and minor axis dimensions are 10m and 6m respectively. Draw profile of the flowerbed by concentric circles method.
3. Construct a hyperbola when the distance between the focus and directrix is 40mm. The eccentricity is $\frac{4}{3}$.
4. A circle of diameter 50 mm rolls on the outside of another circle of diameter 180 mm without sliding. Draw the path traced by a point on the smaller circle.
5. A line AB 50 mm long is inclined at an angle of 30° with the H.P. and parallel to the V.P. Draw the projections when the end A is 15 mm in front of the V.P. and 10 mm above the H.P.

Part B

35 marks

6. The Pictorial view of an object is shown in fig.3. Draw the following views to full size scale.

- a) Elevation in the direction of arrow - 15 Marks
- b) Left end elevation - 10 Marks
- c) Plan - 10 Marks

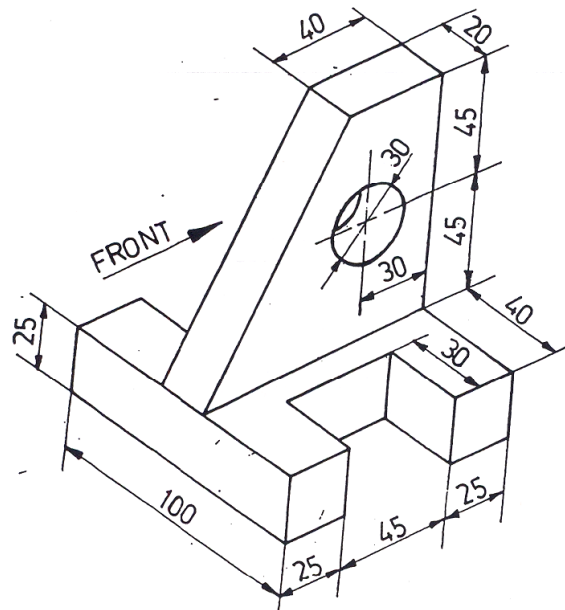

Fig. 3